

Metso

Greatest application fit

Nordberg® GP Series™ cone crushers



Contents

| | | | |
|---------------------------|----|-----------------------------|----|
| Introduction | 3 | GP Series - a summary | 12 |
| Product range | 4 | Technical specifications | 13 |
| Main differences | 5 | Capacity table | 14 |
| GP Versatile | 6 | A look inside | 15 |
| GP Secondary | 7 | Parts and services | 16 |
| How to adjust stroke | 8 | Available cavities | 17 |
| Why to adjust stroke | 9 | Case story: GP500S, Finland | 18 |
| IC50C crusher automation | 10 | Case story: GP330, Germany | 19 |
| IC50C installation layout | 11 | | |

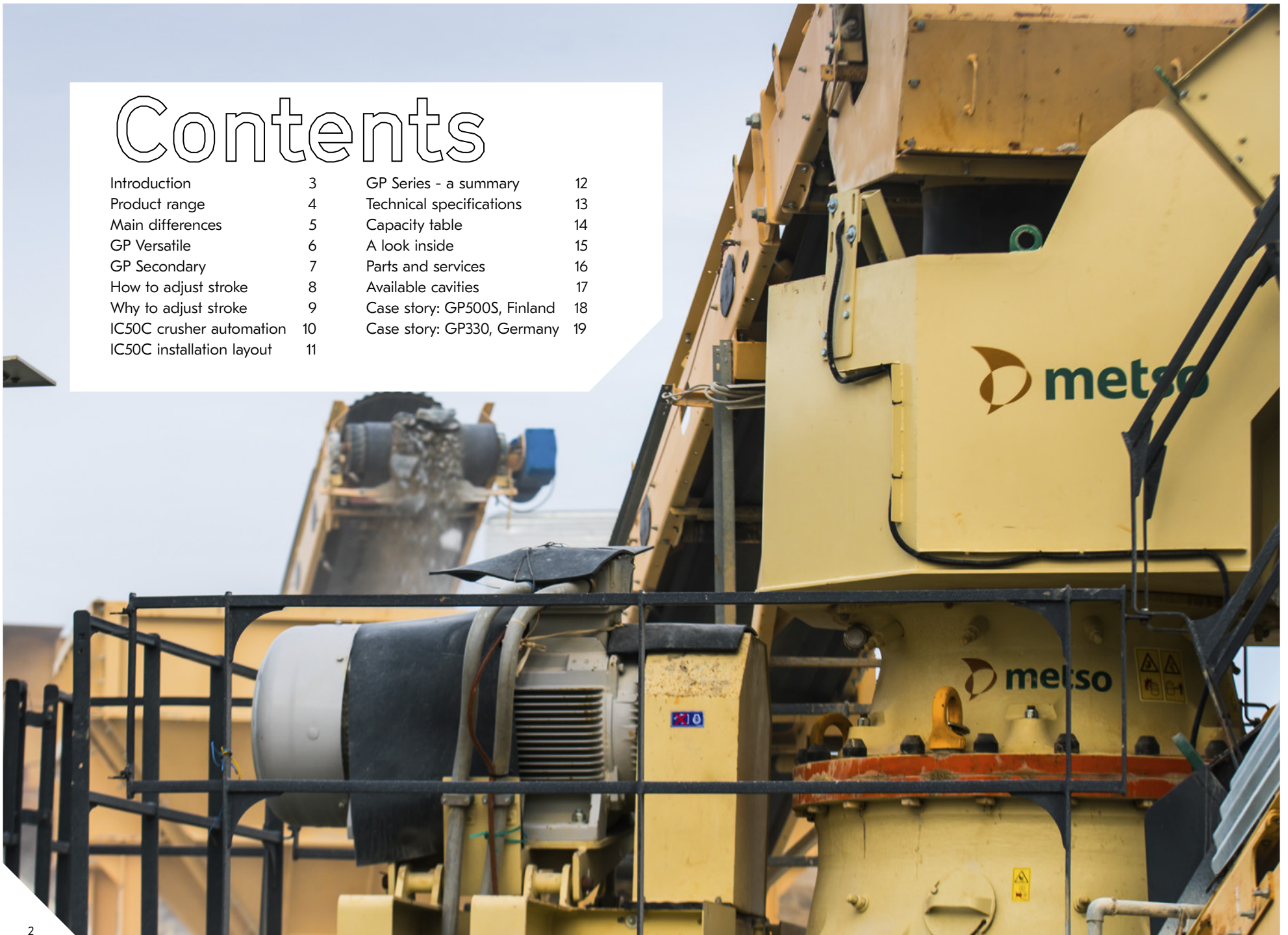



Nordberg® GP Series™ cone crushers

Nordberg GP Series cone crushers are widely and globally utilized in aggregates production and mining operations. The excellent performance-to-footprint ratio and unique cup piston design makes GP cone crushers competitive on all platforms.

Nordberg GP cone crushers have a simple but strong top and bottom supported shaft design, which offers mechanical reliability and has the main shaft participating in the crushing kinematics. Many aspects involved in crusher production, such as stroke length, capacity and quality, are all easily adjusted by rotating the eccentric bushing inside the crusher.

GP cone crushers use IC50C automation system for optimal operating conditions, full crushing stage control, maximized availability and greatest performance with built-in machine protection. The ability to adjust the closed side setting (CSS) under load makes changing end product size effortless and automatic wear part compensation possible, limiting the need to stop the crushing process!

Nordberg® GP Series™ cone crushers family consists of two ranges

The "Secondary" range can be recognized by the letter "S" in their model name and are designed specifically for the secondary crushing applications.

The "Versatile" range can be used in secondary, tertiary and quaternary crushing applications with multiple cavity options and high maximum power ratings.

GP Secondary



| GP100S | |
|----------------------|--------------------------|
| Weight | 7.7 t (17,000 lbs) |
| Power | 75-90 kW (100-125 hp) |
| Maximum feed opening | 236 mm (9 5/16") (C)* |



| GP300S | |
|----------------------|----------------------------|
| Weight | 17.1 t (37,700 lbs) |
| Power | 132-250 kW (175-300 hp) |
| Maximum feed opening | 320 mm (12 5/16") (EC)* |



| GP500S | |
|----------------------|----------------------------|
| Weight | 34.3 t (75,600 lbs) |
| Power | 200-355 kW (275-475 hp) |
| Maximum feed opening | 392 mm (15 1/2") (EC)* |

GP Versatile



| GP100 | |
|----------------------|--------------------------|
| Weight | 6.2 t (13,700 lbs) |
| Power | 75-90 kW (100-125 hp) |
| Maximum feed opening | 135 mm (5 3/16") (C)* |



| GP220 | |
|----------------------|----------------------------|
| Weight | 11.1 t (24,470 lbs) |
| 32-250 | 132-220 kW (175-300 hp) |
| Maximum feed opening | 204 mm (8 1/8") (EC)* |



| GP330 | |
|----------------------|----------------------------|
| Weight | 16.6 t (36,600 lbs) |
| Power | 250-315 kW (325-425 hp) |
| Maximum feed opening | 215 mm (8 1/2") (EC)* |

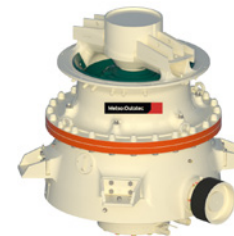

| GP550 | |
|----------------------|----------------------------|
| Weight | 28.7 t (63,300 lbs) |
| Power | 250-400 kW (325-500 hp) |
| Maximum feed opening | 235 mm (9 1/4") (EC)* |

* C = Coarse, EC = Extra Coarse

The three main differences

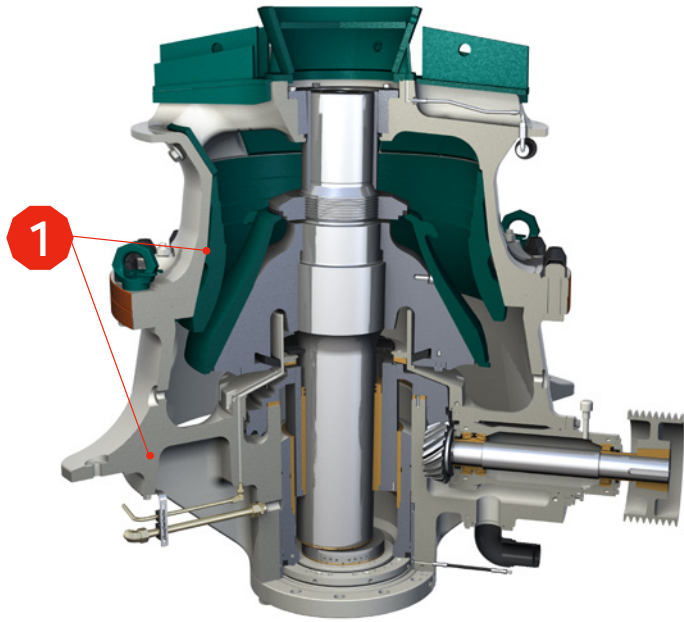

GP Versatile

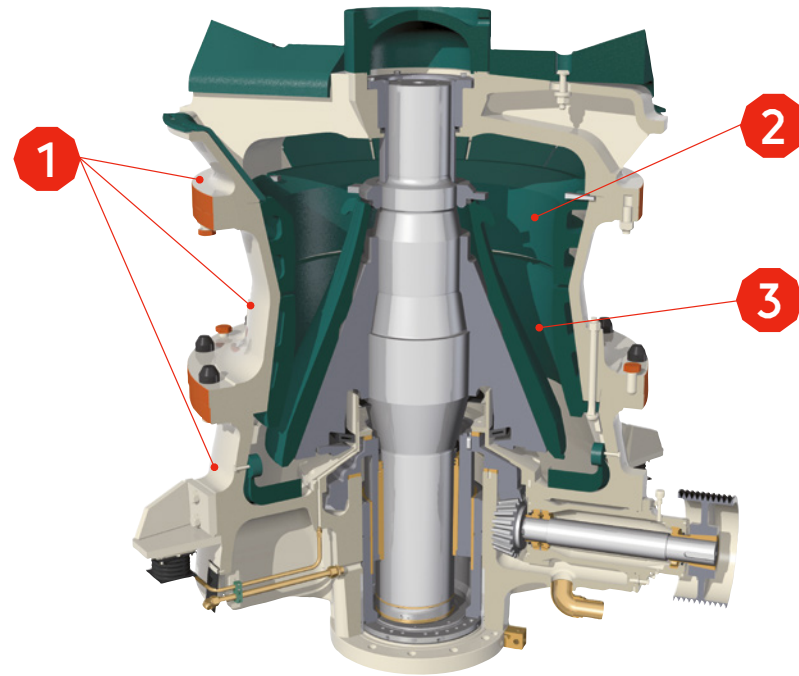

GP Secondary

1. Frame

GP Versatiles are made of two casting frame pieces, and the GP Secondaries from three frame pieces. Compact size of GP Versatiles with high maximum power rating means great power-to-weight ratio and smaller investment required for steel structures. Both GP ranges have a cup piston design, which saves space underneath the crusher.

2. Feed opening

The main feature of the GP Secondaries is the capability to accept extra-large feed material in relation to their physical size, helping our customers in optimizing their capital expenditures. This feature also helps to reduce operating expenses by allowing larger CSS for primary crusher elongating the wear part lifetime, and helps to maximize uptime by minimizing blockages.

3. Cavity profile

GP Versatiles have multiple cavity profiles available for secondary, tertiary and quaternary stage. GP Secondary with its steeper cavity, helps to prevent packing issues, and handle all-in feed better. Also, material throughput is maximized by gravity. GP100S, GP300S and GP500S have separate upper and lower bowl liners which can be changed independently. As the lower one wears out faster, this will help with wear part scrap rate as you can change just the lower bowl liner independently.

GP Versatile cones can be adjusted for any application need

The optimized design of the castings together with IC50C automation makes it possible to use a higher power rating than any other cone crusher with an equal head diameter. Despite the excellent performance, GP Versatiles are quite compact crushers, highlighted by the cup piston design which saves space underneath the GP crusher. Excellent power-to-footprint ratio requires smaller steel structure investments, making crusher replacements much more straightforward.

| | GP100 | GP220 | GP330 | GP550 |
|--------------------------|--------------|---------------|---------------|---------------|
| Max power rating kW (hp) | 90 (125) | 220 (300) | 315 (400) | 400 (500) |
| Head Diameter mm (") | 770 (30 1/3) | 940 (37) | 1167 (46) | 1380 (54 1/3) |
| Weight kg (lbs) | 6.2 (13,700) | 11.1 (24,470) | 16.6 (36,600) | 28.7 (63,300) |

Multiple different cavity profiles provide the perfect application fit for every crushing stage. The longest possible main shaft travel length allows excellent manganese wear part utilization (scrap rate), which results in less frequent liner changes and less waste. That is also why it's possible for GP crushers to use extremely thick and heavy wear parts. That's not all, as GP's uniquely high pivot point (located in the middle of the top bearing) ensures the stroke at the top of the cavity is horizontal, further improving the lifetime due to less attrition and scratching. High pivot point also helps with sticky or wet feed material flow. GP cone crushers have been designed to maximize the feed material flow inside the crusher, e.g. by maximizing the open discharge area in the lower frame.

GP cones performance is less sensitive to the feed material level in the cavity, which is another very important unique feature. They can mechanically tolerate on/off feed and even run empty for long periods of time with no issues due to the mainshaft being supported from top and bottom. If the feed rate and feed level in the cavity is up and down – GP cone crusher is your choice.





GP Secondary – the trouble-free solution to all secondary applications

The Nordberg® GP Series™ Secondary range is designed for demanding secondary crushing where the feed flow varies, and the feed size can be extremely coarse and large, sometimes including high amount of fines as well.

GP Secondaries main feature is to take in extra-large feed material versus their physical size. In a situation called bridging or blockage, too coarse or slabby feed material may get stuck in the feed opening of a cone crusher, thus blocking other material from entering the cavity. The big feed opening and lifted spider arms of the GP Secondary cone crusher help by enabling smooth flow of even the coarsest feed material by preventing the formation of blockages.

This unique “feed opening to weight ratio” creates numerous possibilities for our customers to optimize their operating expenses, like enabling the primary gyratory or jaw crusher to operate with more open closed side setting, prolonging the wear life of jaw dies.

The GP Secondary crushers also have a steep and long vertical cavity. Thanks to this feature, it's possible to run trouble-free operation when the feed material is slabby, slippery or moist. The long steep cavity and the possibility to obtain a shorter stroke helps to prevent packing issues and handle all-in feed!

| | GP100S | GP300S | GP500S |
|-----------------------------|-------------------|--------------------|-------------------|
| Maximum feed opening mm (") | 236 mm (9 19/64") | 320 mm (12 19/32") | 392 mm (15 7/16") |



How to change the stroke

Perhaps the most significant unique feature of the GP cone crushers is the ability to easily change the stroke length by rotating the eccentric bushing inside the crusher (see image on the right).

Stroke is the distance which mainshaft and mantle moves during one eccentric rotation. It's defined by the combined eccentricity of the shaft and bushing (see image below).

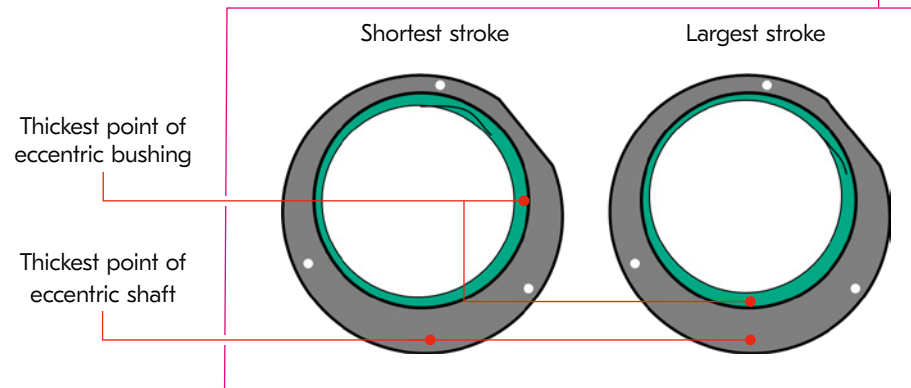
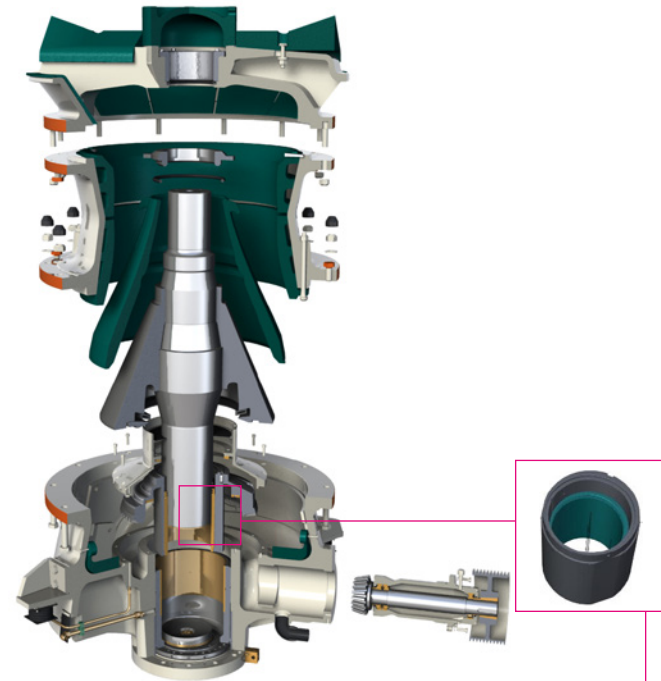
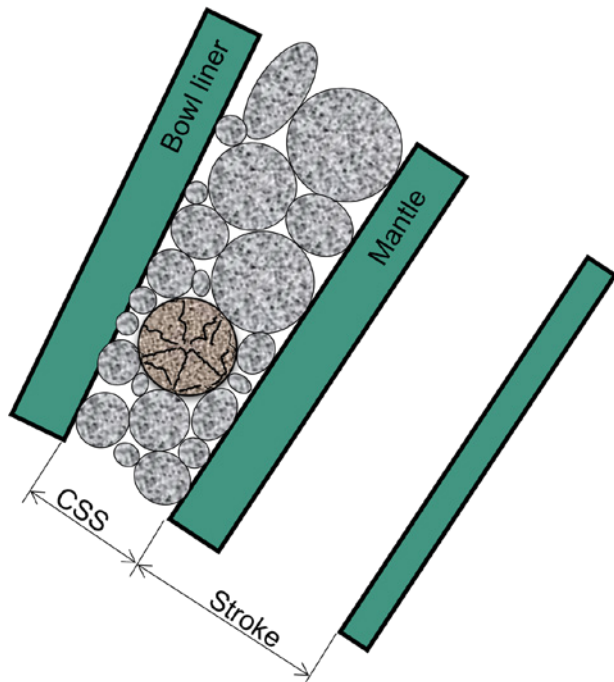

Stroke length is defined by the combined eccentricity of the shaft and bushing

Stroke length adjustment for greatest application fit

Longer stroke means higher capacity and more power draw.

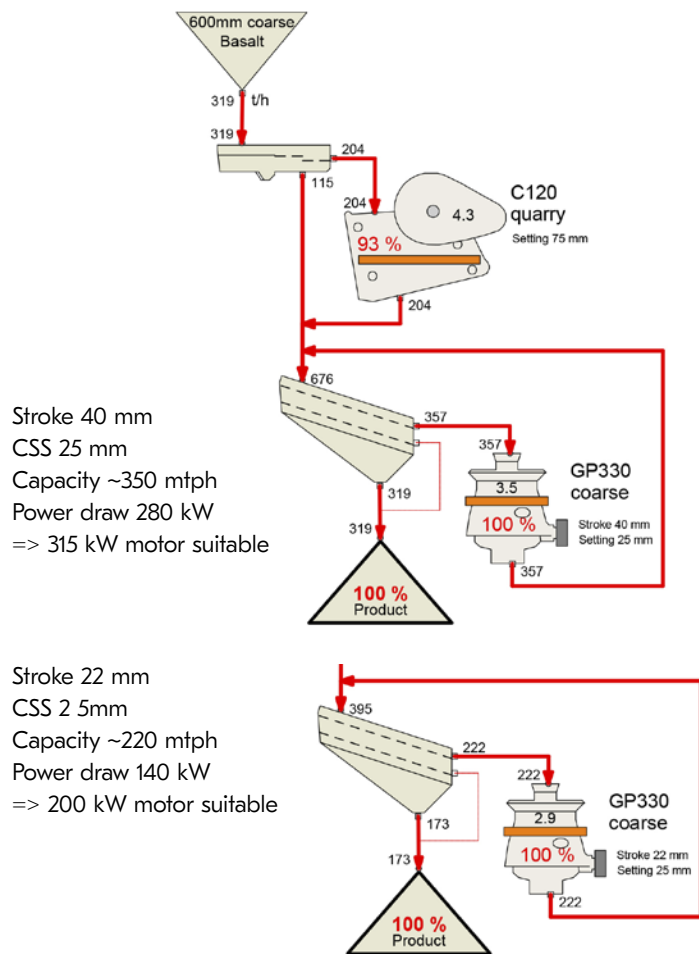

When and why to consider medium and shorter stroke lengths

- Stroke adjustment enables choke fed condition for different feed rates. Choke feed maximizes capacity, shape and reduction ratio.
- Short stroke lowers power draw and piston pressure and helps the crusher to reach tighter CSS. Typically best product shape and size fraction share is achieved around the CSS.
- Short stroke minimizes sand and fines production.
- Short stroke reduces top size of the product to decrease recirculation load.
- Shorter stroke decreases the packing risk if lots of fines are fed to the GP crusher.

GP330, C cavity, CSS 25mm

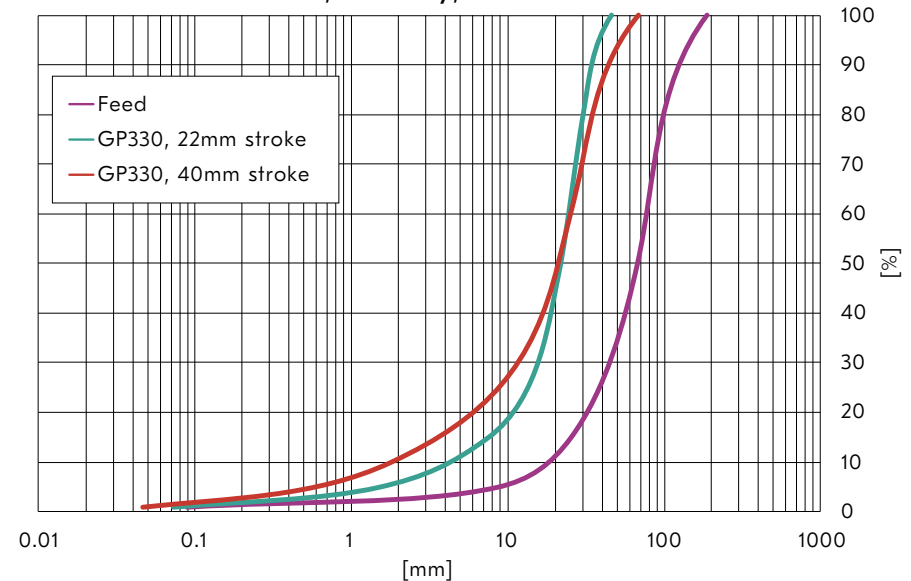

The leading crusher automation – IC50C

Metso IC™ crusher automation brings precision and consistency to your crushing operations. Optimized start-up and shut-down procedures, feed rate control, wear compensation, contact calibration and other sequences ensure that the crusher is working correctly in all circumstances and that the downtime of the crusher is minimal. This leads to predictable and stable production throughput and end-product quality, and thus ensures profitable operation of the crusher and the whole crushing plant.

IC50C maximizes the performance of the GP Series cone crushers. This is done with carefully defined safety parameters for oil temperature, power draw, and hydraulic oil pressure, which are indicators of the actual crusher load. Having automation means it is possible to take every inch of available performance from the crusher in a safe manner, maximizing the utilization of the investment. IC50C has a load indicator which visualizes the maximum and average crushing power and pressure and helps to understand process stability and feed distribution. Automation also monitors the crusher condition and gives an early indication if there's a problem in the crusher or in the application itself. This can help solve a problem before it becomes serious and costly, promoting preventive maintenance.

IC™ crusher automation can be easily connected to any plant automation system used in the crushing and screening industry. This enables centralized control of the crusher and the whole plant, allowing the operator to safely control and alter crusher operating parameters according to production needs from a single location, away from traffic, dust and noise.

C50C in a summary:

- Consistent and precise performance
- Continuous monitoring and control to minimize risks
- Remote control possibility improves operator safety and control



IC50C installation layout

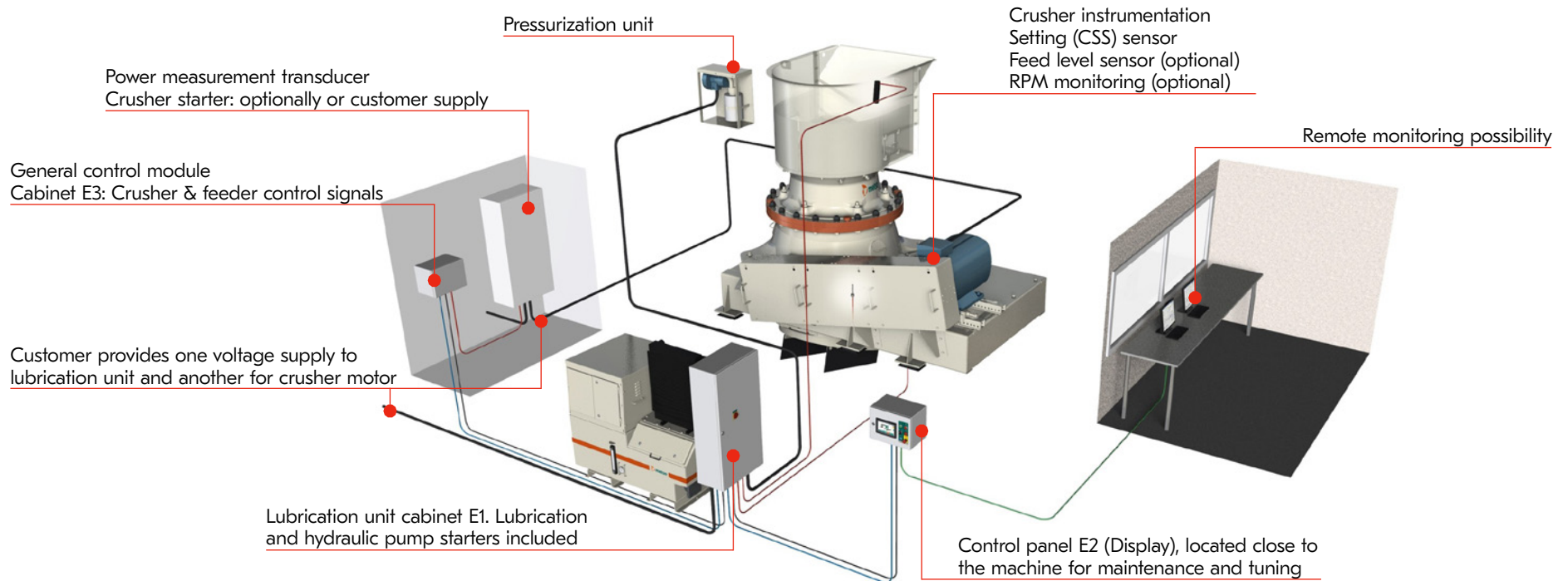

Main features of IC50C as standard

- IC50C includes all of the electrical components needed to operate and monitor the lubrication and hydraulic unit. Lubrication unit instrumentation as well as power cabling are prewired at factory
- Automatic control of the pressurization unit that prevents dust from entering the crusher
- All components, even the display, can withstand extremely harsh conditions
- Connectivity to plant automation with Modbus/TCP (other protocols as an option), providing full integration for customer's SCADA system
- Automated sequences for starting and stopping the process
- Automatic feed rate control to stabilize material level in crusher (feeder VSD not included)
- Ability to start and stop conveyors before and after the crusher in automated sequence
- Crusher closed side setting (CSS) control during crushing with two modes:
 - Setting mode to keep CSS at user preset value
 - Load mode for adjusting CSS based on wanted power or pressure target to achieve maximum production regardless of changes in the feed or wear of the liners
- Safer and faster automatic contact calibration for GP220, GP330 and GP550
- Automatic wear compensation while crusher is under load to keep the CSS constant between calibrations
- Warming mode to keep crusher and lubrication unit ready to start at all times even during cold season
- Metrics fleet management
- Local data logging, export to USB

Nordberg GP Series cone crushers

The excellent performance-to-footprint ratio and unique cup piston design makes GP cone crushers competitive on all platforms.

Nordberg GP cone crushers have a simple but strong top and bottom supported shaft design which offers mechanical reliability, and where the main shaft participated in the crushing kinematics.

GP cone crushers have IC50C automation system for optimal operating conditions, full crushing stage control, maximized availability and greatest performance with built-in machine protection. The ability to adjust the closed side setting (CSS) under load makes changing end product size effortless and automatic wear part compensation possible.

1 Especially the GP Secondary models have massive feed opening, which stays constant throughout the wear part lifetime GP cones can also tolerate on/off feeding and running with empty cavity.

2 No backing material needed for wear part installation! Very little head spin with long vertical main shaft travel range enables high utilization of the manganese.

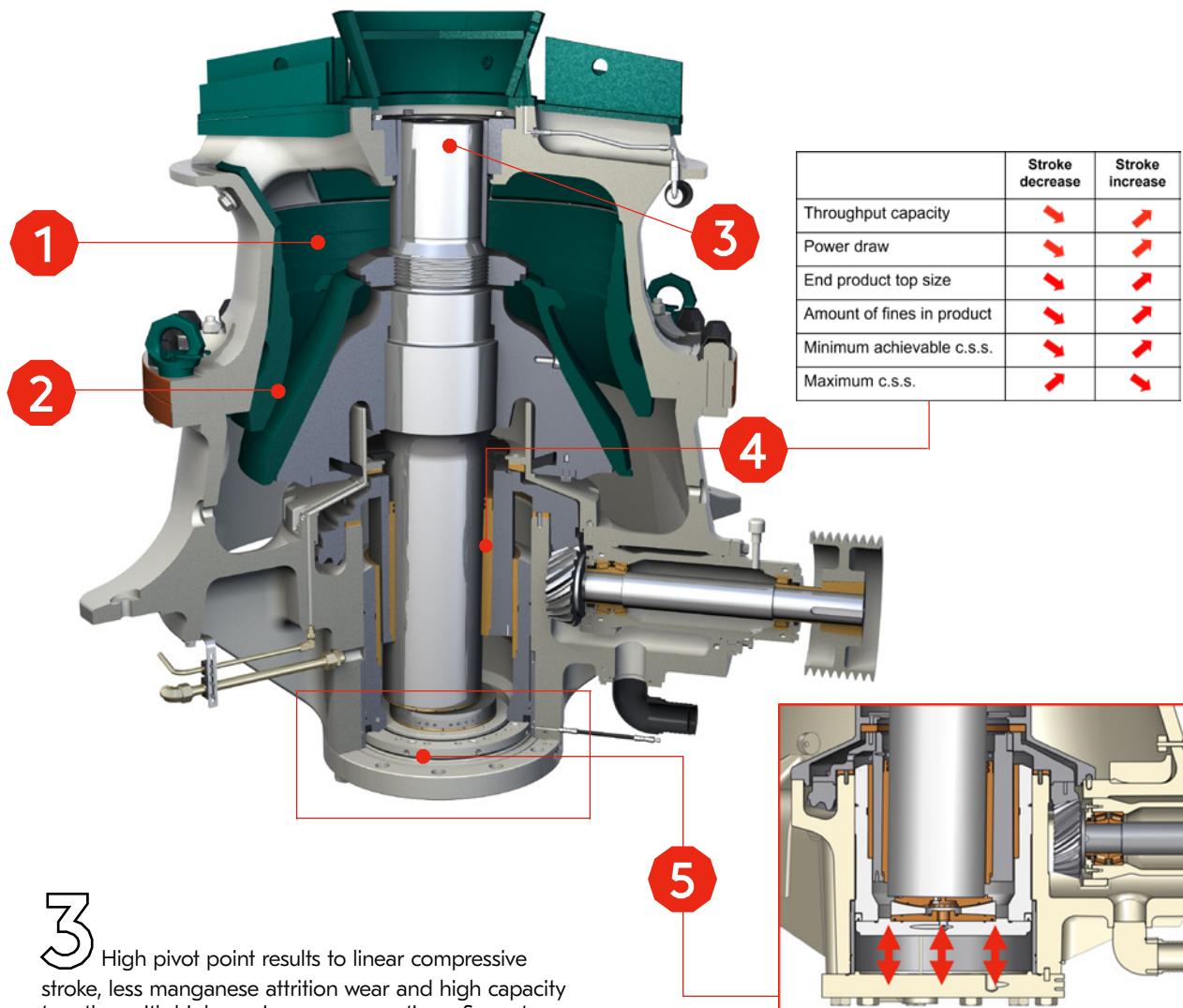

3 High pivot point results to linear compressive stroke, less manganese attrition wear and high capacity together with high maximum power ratings. Same top bearing can be used with all of the stroke length options.

4 The stroke length and thus many aspects of the production of the crusher are easily adjustable by rotating or swapping the eccentric bronze bushing inside the crusher.

5 CSS of the GP™ cone can be adjusted during crushing by the oil volume under the main shaft via the IC50C automation, also making e.g. wear compensation possible!

Technical specifications Nordberg® GP Series™ cone crushers

| | GP100S™ | GP300S™ | GP500S™ | GP100™ | GP220™ | GP330™ | GP550™ |
|----------------------|-----------------------------------|---|--|-----------------------------------|--|---|---|
| Crushing range | Secondary | Secondary | Secondary | Secondary, tertiary, quaternary | Secondary, tertiary, quaternary | Secondary, tertiary, quaternary | Secondary, tertiary, quaternary |
| Weight* | 7.7 t (17,000 lbs) | 17.1 t (37,700 lbs) | 34.3 t (75,600 lbs) | 6.2 t (13,700 lbs) | 11.1 t (24,470 lbs) | 16.6 t (36,600 lbs) | 28.7 t (63,300 lbs) |
| Power | 75 - 90 kW (100 - 125 hp) | 132 - 250 kW (175 - 300 hp) | 200 - 355 kW (275 - 475 hp) | 75 - 90 kW (100 - 125 hp) | 132 - 220 kW (175 - 300 hp) | 250 - 315 kW (325 - 425 hp) | 250 - 400 kW (325 - 500 hp) |
| Maximum feed opening | 236 mm (9 1/4") | 320 mm (12 1/2") | 392 mm (15 3/8") | 135 mm (5 3/8") | 204 mm (8 1/2") | 215 mm (8 1/2") | 235 mm (9 1/4") |
| Stroke options | 16, 20, 25 mm (5/8, 13/16, 1") | 18, 22, 25, 28, 32, 36 mm (1/16, 7/8, 1, 1 1/4, 1 1/2, 1 13/32") | 18, 25, 28, 32, 36, 40 mm (1/16, 1, 1 1/4, 1 1/2, 1 13/32, 1 1/16") | 16, 20, 25 mm (5/8, 13/16, 1") | 18, 25, 28, 32, 36, 40 mm (1/16, 1, 1 1/4, 1 1/2, 1 13/32, 1 1/16") | 18, 22, 25, 28, 32, 36, 40 mm (1/16, 7/8, 1, 1 1/4, 1 1/2, 1 13/32, 1 1/16") | 25, 28, 32, 36, 40, 45 mm (1, 1 1/4, 1 1/2, 1 13/32, 1 1/16, 1 25/32") |

* Bare crusher weight

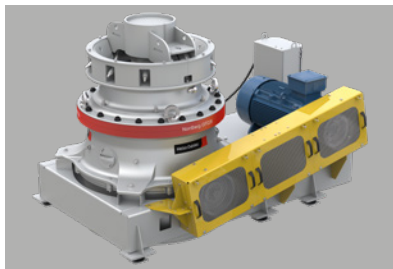

Options include sub frame, motor, guards for the drive system.



Options also include feed and discharge chutes, integrated and separate motor supports.



IC50C automation always part of the delivery scope.



Many service tools for safe maintenance are available!

Capacity table

Figures in the table represent the crusher capacities, which are based on a feed material with an average specific gravity of 2,7 t/m³, a maximum feed size that will enter the crusher without bridging per appropriate cavity profile and stroke length, and in a situation where the feed includes equal or less than 30% of material finer than the crusher closed side setting.

The capacities and possible achievable minimum closed side setting used may vary depending on the feeding method and on feed characteristics such as gradation, bulk density and moisture, clay content and crushability.

| Crusher throughput capacity | | | | | | | |
|-----------------------------|---------|---------|---------|--------|---------|---------|---------|
| Closed side setting | GP100S | GP300S | GP500S | GP100 | GP220 | GP330 | GP550 |
| 6 mm | | | | 35-50 | | | |
| 3/16" | | | | 39-55 | | | |
| 8 mm | | | | 40-65 | 70-90 | 105-145 | |
| 5/16" | | | | 44-72 | 77-99 | 116-160 | |
| 10 mm | | | | 45-73 | 80-130 | 110-190 | |
| 3/8" | | | | 49-80 | 88-143 | 121-210 | |
| 15 mm | | | | 50-95 | 105-175 | 130-260 | 160-310 |
| 19/32" | | | | 55-105 | 115-192 | 143-286 | 176-341 |
| 20 mm | 80-120 | | | 65-105 | 120-230 | 155-300 | 190-340 |
| 25/32" | 88-132 | | | 72-116 | 132-253 | 170-330 | 209-374 |
| 25 mm | 105-165 | 180-260 | | | 150-265 | 180-350 | 230-410 |
| 1" | 116-182 | 198-286 | | | 165-292 | 198-385 | 253-451 |
| 30 mm | 120-195 | 190-340 | | | 165-280 | 210-390 | 250-450 |
| 1 3/16" | 132-214 | 209-374 | | | 182-308 | 230-430 | 275-495 |
| 35 mm | 135-220 | 200-400 | 250-540 | | 180-310 | 230-420 | 280-510 |
| 1 3/8" | 149-242 | 220-440 | 275-594 | | 198-341 | 256-462 | 308-561 |
| 40 mm | 145-230 | 215-440 | 275-600 | | | | 310-540 |
| 1 1/16" | 160-253 | 236-484 | 303-660 | | | | 341-594 |
| 45 mm | 155-250 | 235-460 | 300-660 | | | | 340-575 |
| 1 3/4" | 170-275 | 259-506 | 330-726 | | | | 374-633 |
| 50 mm | | 260-480 | 360-720 | | | | |
| 2" | | 286-528 | 396-792 | | | | |
| 55 mm | | | 400-780 | | | | |
| 2 3/16" | | | 440-858 | | | | |
| 60 mm | | | 450-820 | | | | |
| 2 3/8" | | | 495-902 | | | | |
| 65 mm | | | 470-860 | | | | *mtph |
| 2 1/16" | | | 517-946 | | | | **stph |

A look inside

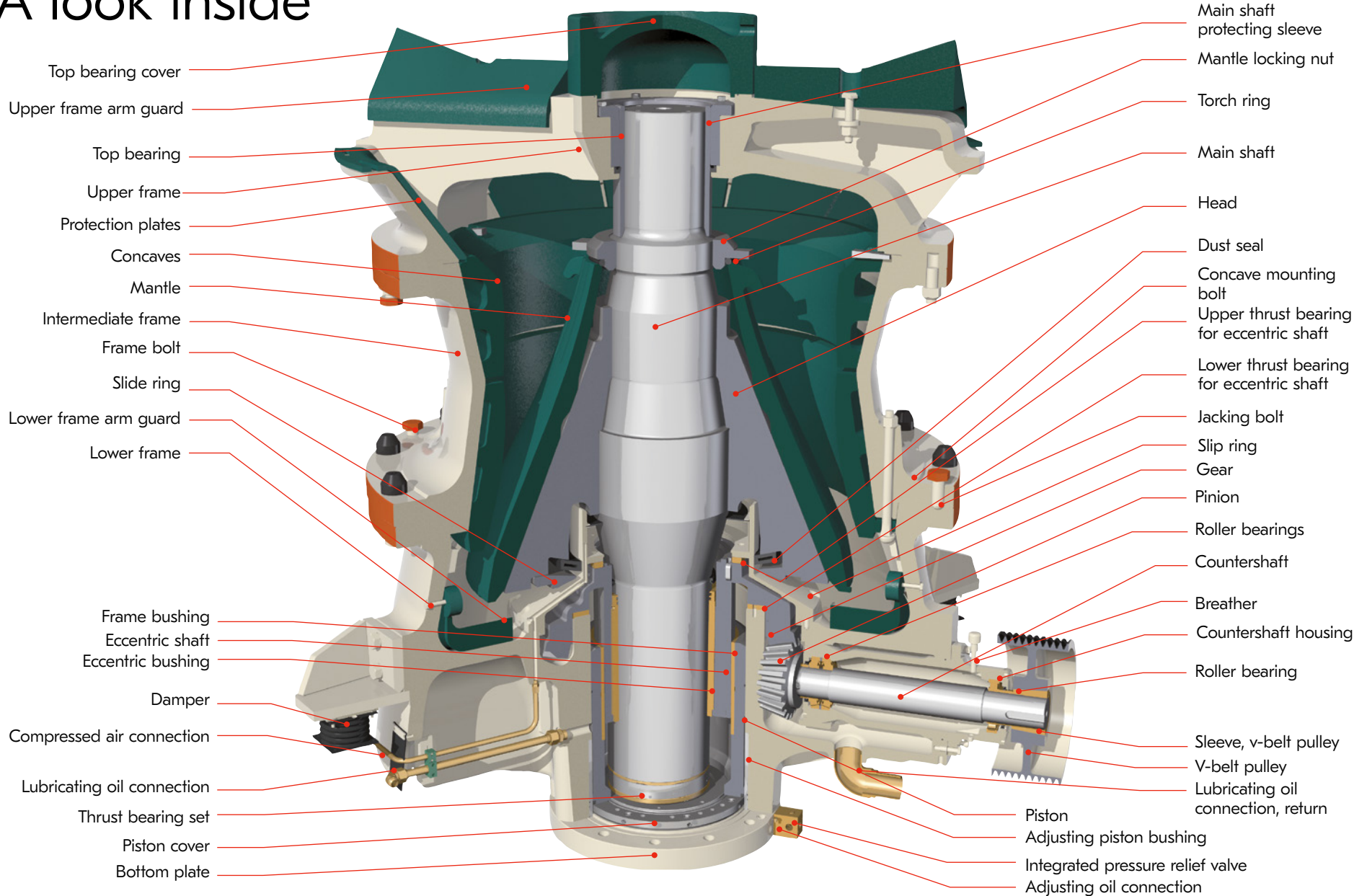

Parts and services

Genuine Metso OEM wear and spare parts are the best choice to minimize maintenance issues and increase longevity, improving the sustainability of the operations at the site. Our global distribution logistics network ensures that Metso OEM spare and wear parts are available when you need them. With both standard and engineered-to-order parts, Metso can ensure that you have the support your crushers need.

Our service offering ensures that you get the best out of your GP cone crusher. This includes maintenance and repair services, equipment upgrades and retrofits, process optimization and controls, and Life Cycle Services. Together with our expertise, these services can help you reach your production goals, improve your crushing process and extend the productive lifetime of your cone crusher.

Whenever service is required, Nordberg® GP™ crushers can be disassembled from above, and all heavy components can be lifted.

Top service

- Easy to dismantle the crusher for service and for liner change
- Access into the machine internals from the top
- Safe and easy for lifting parts in and out
- Quick and safe maintenance
- Good up-time
- Service tools



Nordberg GP550
crusher

A wide selection of cavities for the greatest application fit

Our selection of cone crusher wear parts ensures that there is a solution for your application. We have the expertise to select both the chamber and the alloy to fit your crushing operation. The right wear profile improves crusher performance and extends wear life, leading to less downtime and fewer liner replacements, which in turn increases safety and reduces the cost per ton. We also offer lifting tools to make the cone crusher maintenance safer and more efficient.

With GP cone crushers backing material is not needed for manganese wear part installation. Bowl liners / concaves and mantles are machined for good fit and for good seating surface against the head and upper frame(s).

Wear part offering:

- Mantles
- Bowl liners / concaves
- Feed cones
- Main frame liners
- Protection cones
- Arm guards
- Wear part fastening items

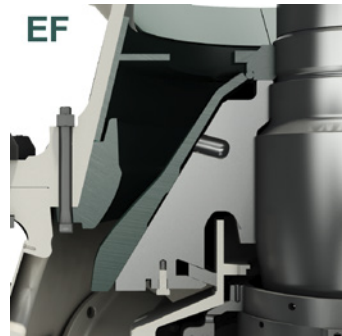

GP100 EF, GP220 EF,
GP330 EF, GP550 EF

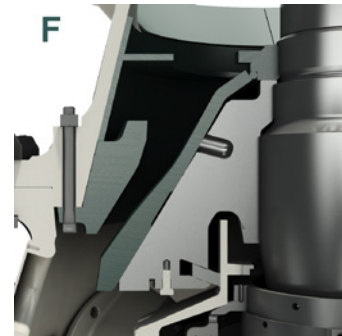

GP100 F, GP220 F,
GP330 F, GP550 F

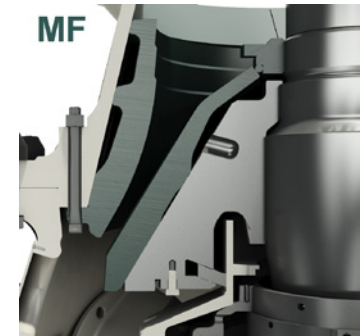

GP100 MF, GP220 MF,
GP330 MF, GP550 MF

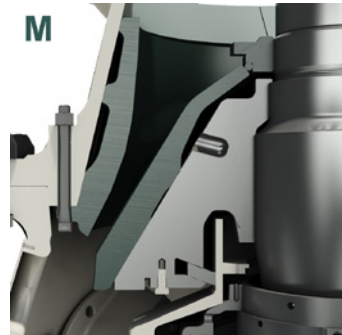

GP100 M, GP220 M,
GP330 M, GP550 M

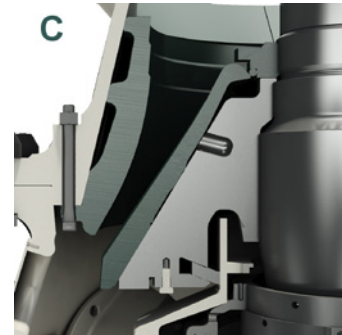

GP100 C, GP11M C, GP220 C,
GP330 C, GP550 C



GP220 EC, GP330 EC,
GP550 EC

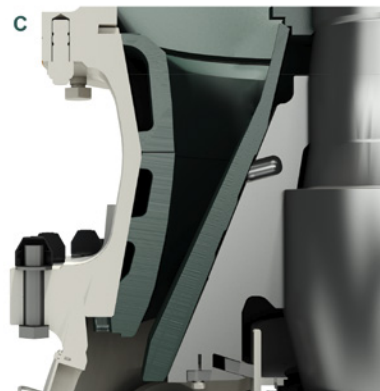

GP100S M, GP300S C,
GP500S C



GP100S C, GP300S EC,
GP500S EC

Nordkalk's GP500S secondary crusher has doubled the crushing ratio and facilitates process adjustability

A doubling of the crushing ratio, a more easily adjustable process, and a massive intake feed opening that prevents blockages in the crusher are the key benefits that Nordkalk Corporation's Lappeenranta mine in Finland achieved with a recently installed secondary crusher, the Nordberg GP500S.

"The large feed opening reduces the risk of blockages in the crusher. In addition, we can use the modern IC50C automation of the GP500S to adjust the crusher's CSS much more accurately than before. This is important, as we process a variety of minerals with very different characteristics.

At present, the capacity of our crushing process is some 400 metric tons with 25 mm stroke, EC liners and roughly 30-35 mm CSS. The new GP500S with adjustable stroke length will allow us to increase the capacity in future if we decide to renovate other parts of the rock line" Petri Repo, Maintenance Manager sums up.

GP500S receives feed of 0-200 mm, which is crushed to 38-45 mm before further fine crushing. Every now and then the GP500S is fed with elongated particles with massive cross-dimension, which is not a problem as the EC cavity can accept almost 450 mm sized feed. After crushing, the material is taken to silos or storage piles, from where the different types of material are supplied to a cement mill or one of the two concentration plants.



Case story:
Nordkalk mine,
Lappeenranta, Finland



The first Nordberg® GP330™ cone crusher in Germany has proven its reliability at the BAG Rammelsbach stone quarry ever since 2016

Operating safety is a top priority for us. With the new Nordberg® GP330™ hydraulic cone crusher, we can guarantee non-stop hassle-free crushing operations in our secondary crushing stage and process up to 4,000 tons of top-quality rock each day” says Kurt Schön, production manager at the BAG Rammelsbach stone quarry.

The extracted microdiorite is transported via dump truck to the gyratory primary crusher. Afterwards, the product is screened into three sizes: The 0-32 mm material is separated from the rest of the feed, and 32-70 mm and 70-240 mm is stored temporarily in silos and then transferred via feed conveyors to the Nordberg GP330 hydraulic cone crusher.

The GP330 produces well-shaped material with a size of 0-80 mm at a constant throughput of 340 t/h for further processing. The cone crusher has Extra Coarse (EC) cavity profile, approximately 34 mm closed side setting (CSS) and 32 mm stroke length. Stroke can be adjusted by rotating the eccentric bushing inside the crusher, which is a distinct feature of all the Nordberg GP cone crushers. This allows the GP crushers to be adjusted to match every application’s needs; for example to maximize capacity or to reduce the amount of the produced fines.

GP330 is also easily converted from secondary crushing stage to suit tertiary crushing by just changing out the manganese wear parts, giving it excellent versatility.

Case story:
BAG Rammelsbach
Quarry, Germany

